***Overview***

This tea table makes a great addition to any deck or patio but isn't limited to outdoor use. It could also make a great addition to any interior space.

The overall dimensions of this tea table are 30" x 30" x 29-3/4".

Before Getting Started

Please read and understand this plan package before beginning.

Dimensions are given in the following format:
Length x Width x Height (or Thickness)

Determine what species of wood you will use to complete this project. If you are unsure which species is best suited for this project our project wood at <http://woodworkingplans.ca> . It may be able to help.

Safety

These plans assume that you have a certain level of knowledge about wood working. Since there are many ways to perform one task you must choose the best approach for yourself based on you skill level and tools. If you aren't completely comfortable using a tool, find an alternative way to make the cut.

Remember to always follow the instructions that come with your tools for safe operating procedures.

Warranty

These plans are provided “as is” and all sales are final due to the digital nature of the plans.

However we always value your thought and opinions regarding our plans. If you spot any errors with these plans or if you get stuck and need assistance contact us at dave@woodworkingplans.ca and let us know.

Tools, Wood and Hardware

All tools, hardware and wood for these projects can be found at www.woodworkingplans.ca

Tea Table

This tea table is a great project for your backyard deck. The mortise and tenon joinery make this table strong enough to take the heavy loads of plants or a buffet of food.

Legs – Part A:

There are four legs measuring 1-1/2" x 1-1/2" x 29". The two exterior faces are straight while the two interior faces are tapered from 1-1/2" at the top to 1" at the bottom. This taper is best cut using a tapering jig and the table saw.

The legs also receive several mortises to accept the rails and shelf. See connection detail on page F2.

Upper Rails – Part B:

There are four upper rails measuring 22-1/2" x 3-1/2" x 1", including the tenons. Each rail has a 3/4" long tenon that joins it to the legs. See page F2 for details of the rail layout.

All the top rails have a 1/4" x 1/4" dado milled on the upper inside face to accept wooden clips that attach the top. See rail and top connection detail on page F2.

Lower Rails – Part C:

The two lower rails act to stabilize the table and give it lateral strength. There are two lower rails in total measuring 22-3/4" x 1" x 1", including the tenons.

Pilasters – Part D:

Each rail has a 2-1/2" x 2" x 1/4" pilaster mid span to add a decorative element to the rails See page F2 for detail of pilaster location.

Slats – Part E:

There are six slats in total that provide a decorative feature to this tea table. The slats measure 8-1/2" x 2" x 1/2" including tenons. These slats are joined to the lower table rails and the lower shelf using a mortise and tenon joint.

Shelf – Part F:

The lower shelf is also glued up to form a panel 24" x 24" x 3/4". The lower shelf is attached to the legs with a dado. Be sure not to fix the shelf across the grain since it will expand and contract with changes in humidity.

Also the grain of the lower shelf should run in the same direction as the lower rails to avoid the shelf splitting with seasonal movement.
See shelf connection detail on page F2.

Top – Part G:

The top of the tea table is a glued up panel measuring 30" x 30" x 3/4". The corners are cut to create a 2-1/8" chamfer. The upper edge of the table is detailed with a 1/2" round over bit or chamfer bit.

Materials

Cut List:

Part A - Four Legs @ 29" x 1-1/2" x 1-1/2"
 Part B - Four Upper Rails @ 22-1/2" x 3-1/2" x 1"
 Part C - Two Lower Rails @ 22-3/4" x 1" x 1"
 Part D - Four Pilasters @ 2-1/2" x 2" x 1/4"
 Part E - Six Slats @ 8-1/2" x 2" x 1/2"
 Part F - Shelf @ 24" x 24" x 3/4"
 Part G - Top @ 30" x 30" x 3/4"

Materials:

3 @ 8' x 8" x 1"
 1 @ 4' x 8" x 1" (rough size stock)
 1 @ 8' x 4" x 2"

Disclaimer

These plans make the assumption that you have a basic knowledge of wood working and wood working safety. We can make no guarantee that you have the wood working knowledge to complete this plan and thus assume no responsibility for un-satisfactory results.

Always read and understand the instructions that come with your tools. This will instruct you on the proper use of the tools.

Accurate Woodworking assumes no responsibility for damages (tools, personal, computer or any other damage) resulting from the use of this set of plans.

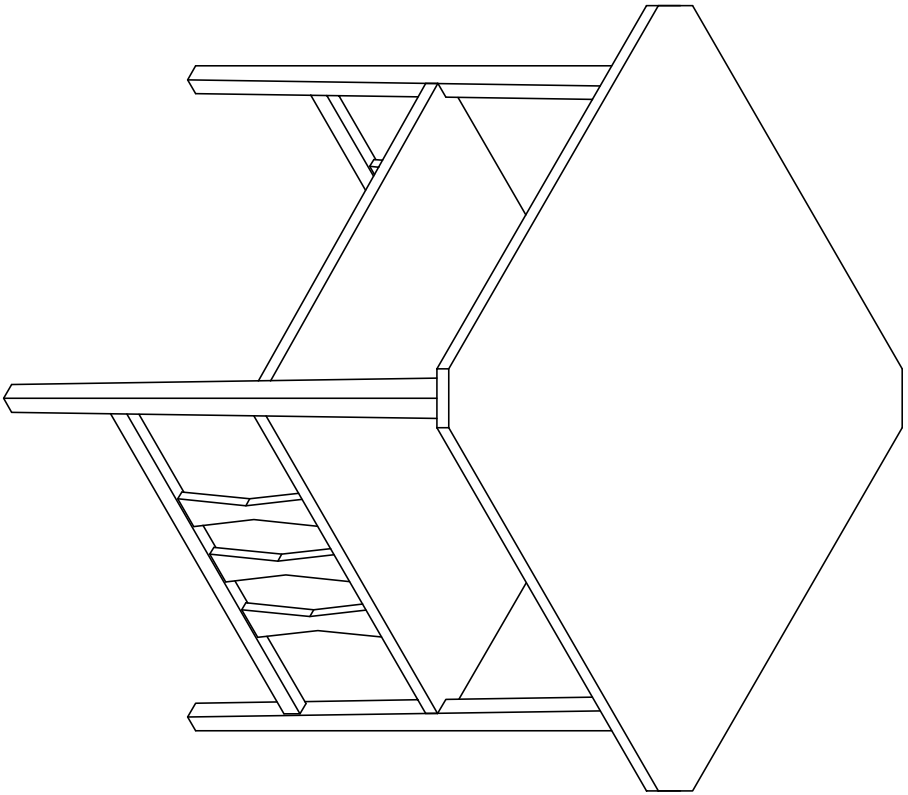

PLAN TITLE
TEA
TABLE

DRAWING TITLE
ISOMETRIC

SCALE
1" = 1'-0"

DRAWN
DEW

DATE
2008

DRAWING NO.

F1

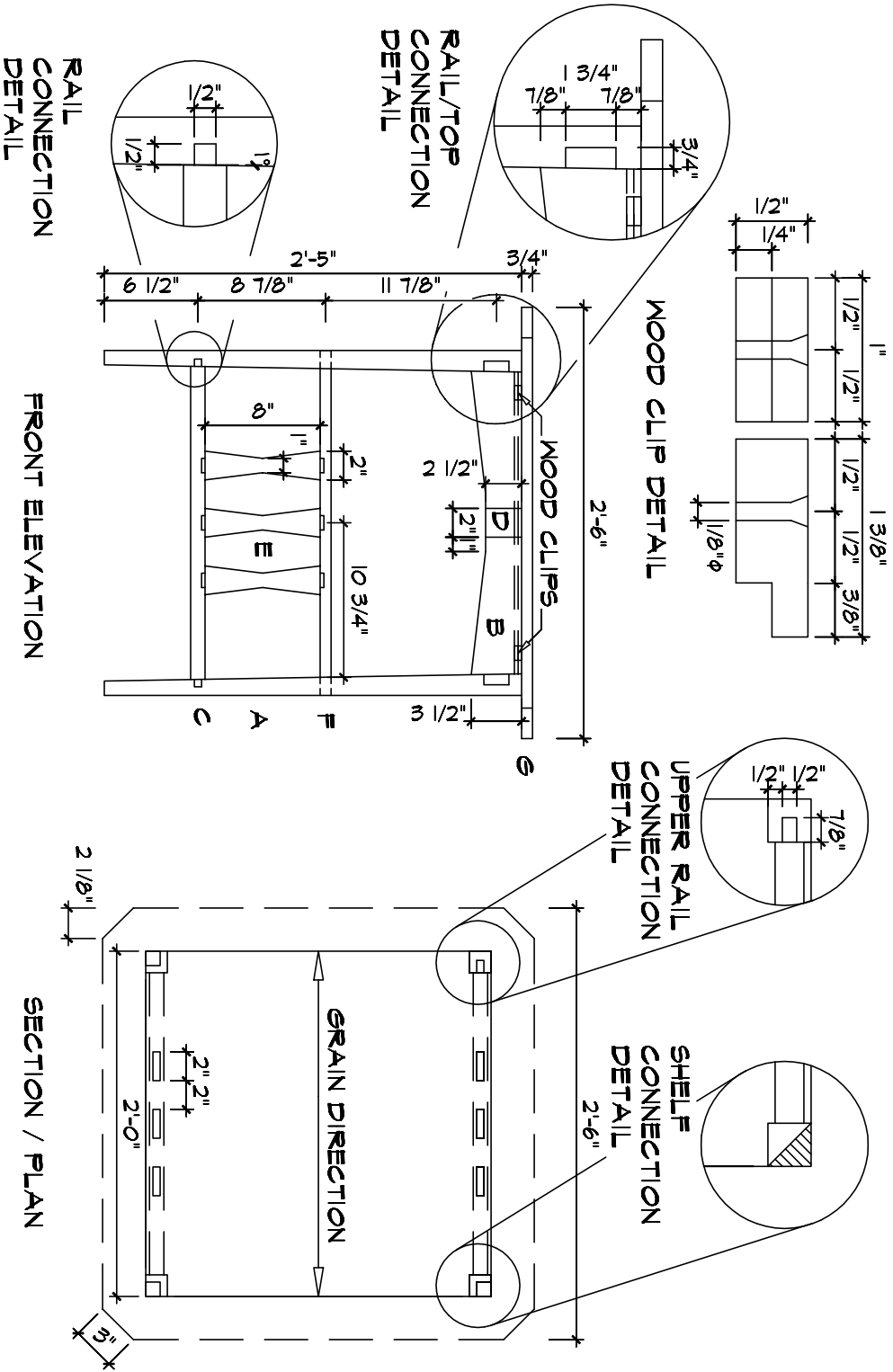

DRAWING NO. F2	DATE 2009	DRAWN DBM	SCALE 1" = 1'-0"	DRAWING TITLE FRONT / TOP VIEW	PLAN TITLE TEA TABLE

8' x 8" x 1"

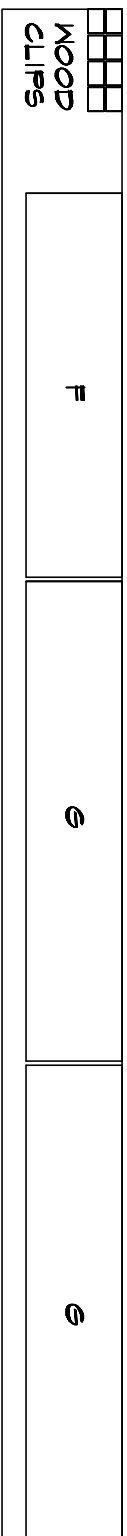

8' x 8" x 1"

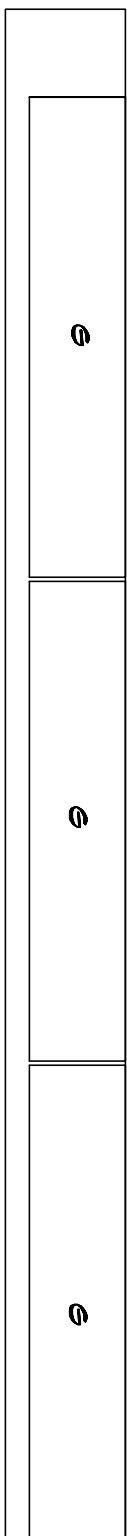

8' x 8" x 1"

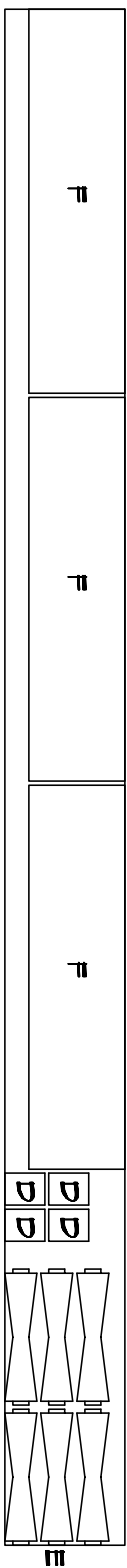

4' x 8" x 1" (ROUGH SIZE)

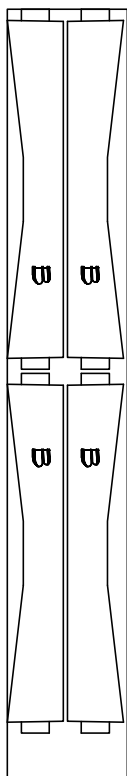

8' x 4" x 2"

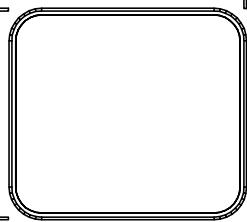

PLAN TITLE
TEA
TABLE

DRAWING TITLE
MATERIALS
LIST

SCALE 1" = 1'-0"

DRAWN DENM

DATE 2009

DRAWING NO.

F3

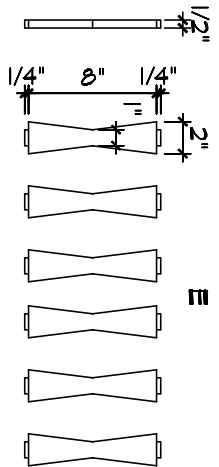
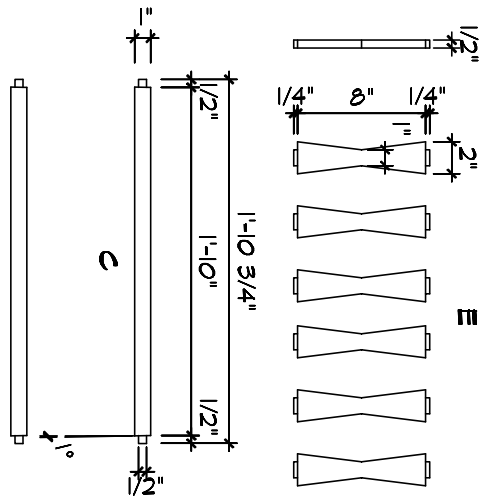
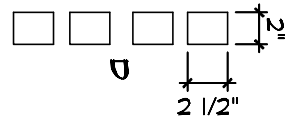
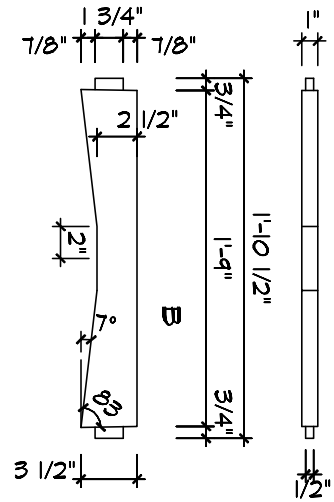
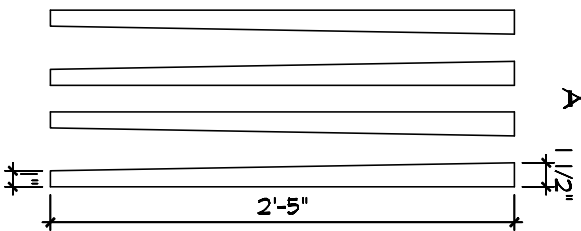
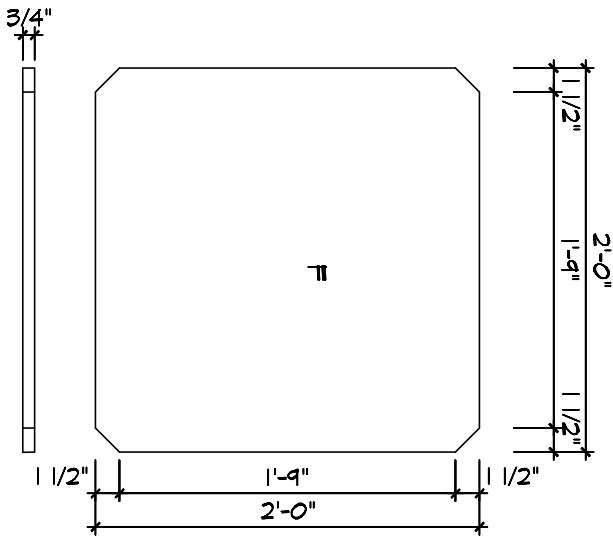
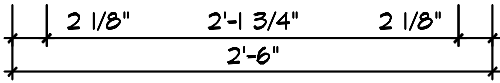
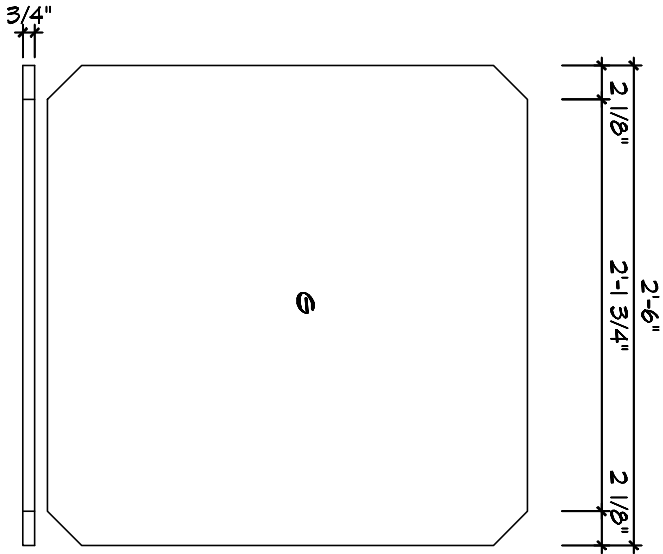

DRAWING NO. F4	
DATE	2008
DRAWN	DEM
SCALE	1"=1'-0"
DRAWING TITLE	
TEA TABLE	
PARTS LIST	